



Assembly Instructions



The Grandverismo Music Mount can be utilized when the piano lid is in both open and closed positions.

Key Piano Anatomy for Grandverismo

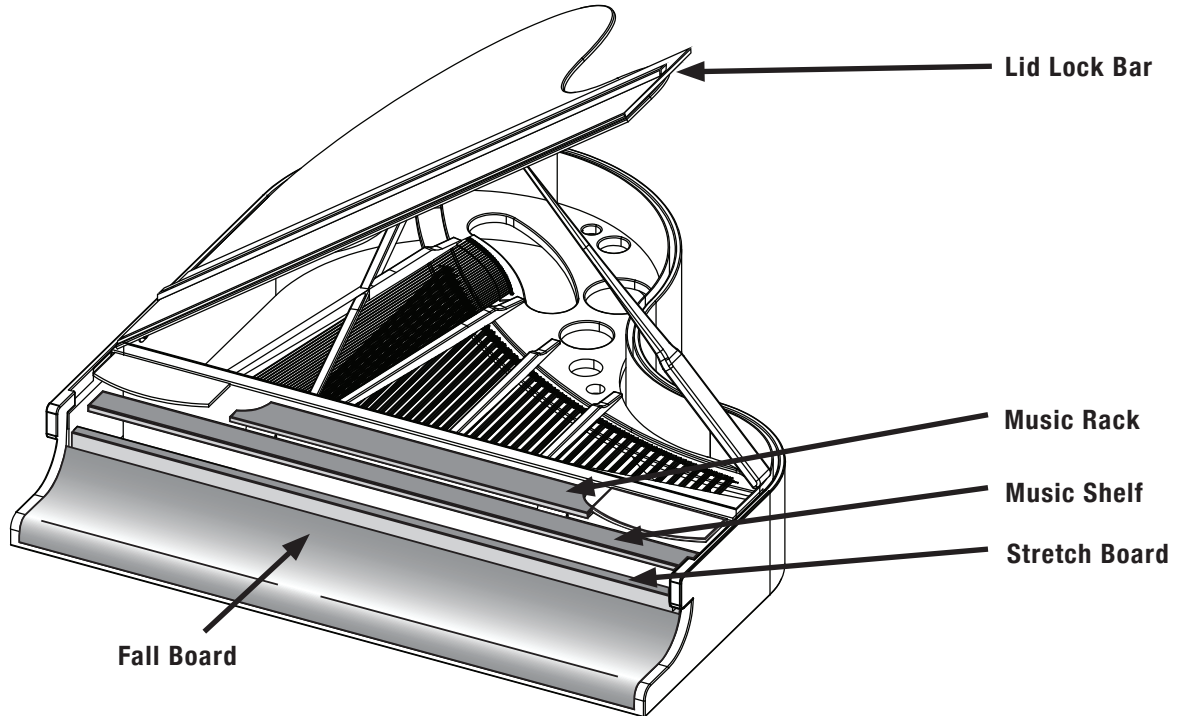

Step 1

PLACEMENT OF 1/4" x 1/4" x 2" STOP FELT

(This step is not necessary for pianos in which the fall board is taller than the stretch board. In such cases, offset brackets are supplied with your Grandverismo music mount which have a built-in stopping mechanism. See **figure 1**)

Place your bracket on the stretch board as shown in **figure 1A**. Position the bracket while opening and closing the piano lid ensuring that there is at least 1/2" clearance between lid and bracket at the closest point of contact. (This is to ensure that brackets do not scrape your piano lid while opening and closing.) With the location noted, peel the sticky backing of the stop felt to reveal the adhesive, then apply the adhesive side of the stop felt to the underside of the bracket, flush with the inside edge of the stretch board. This will prevent the bracket from pulling out from the piano.

Install the stop felt on the second bracket at the same location.

figure 1
(for offset brackets)

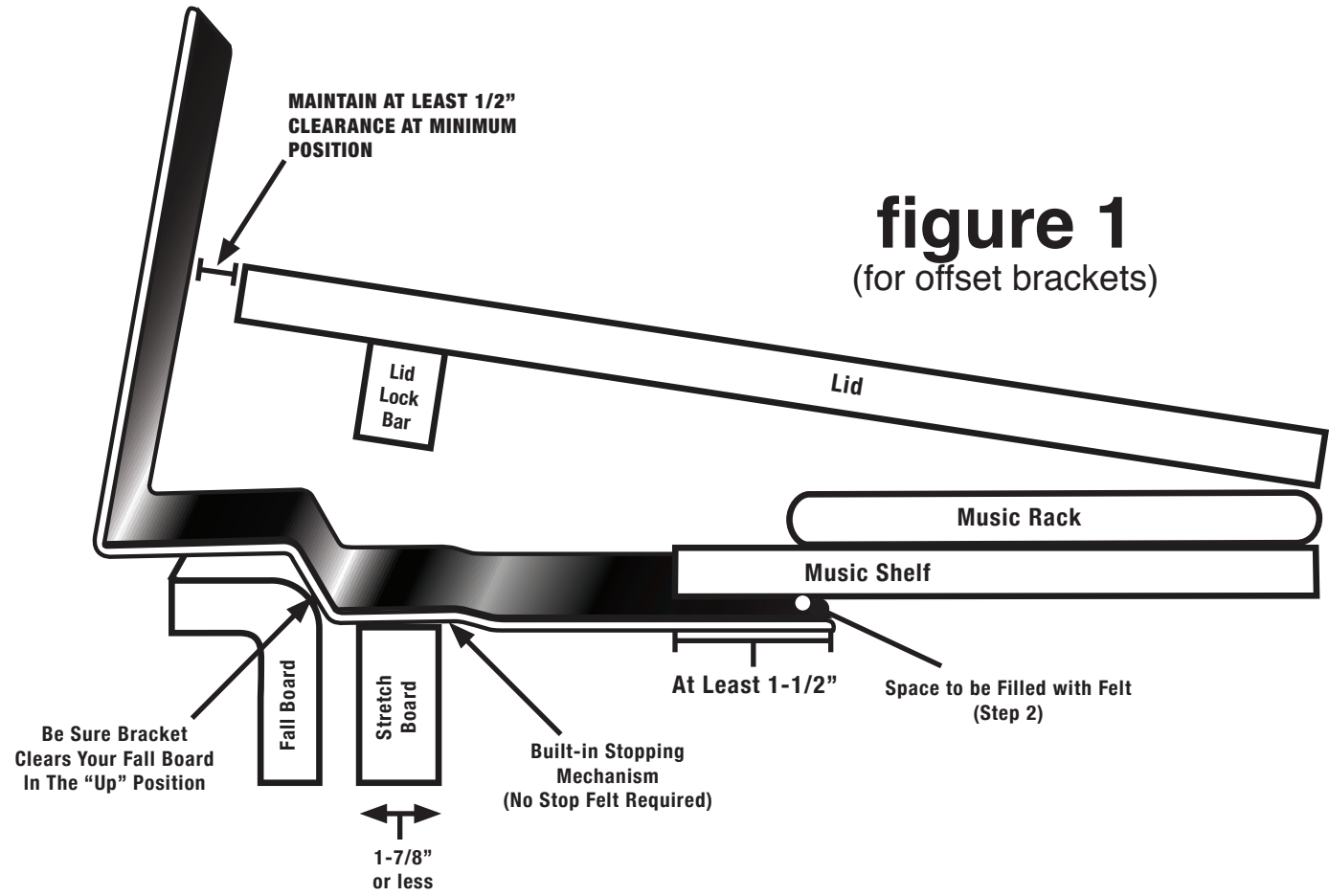

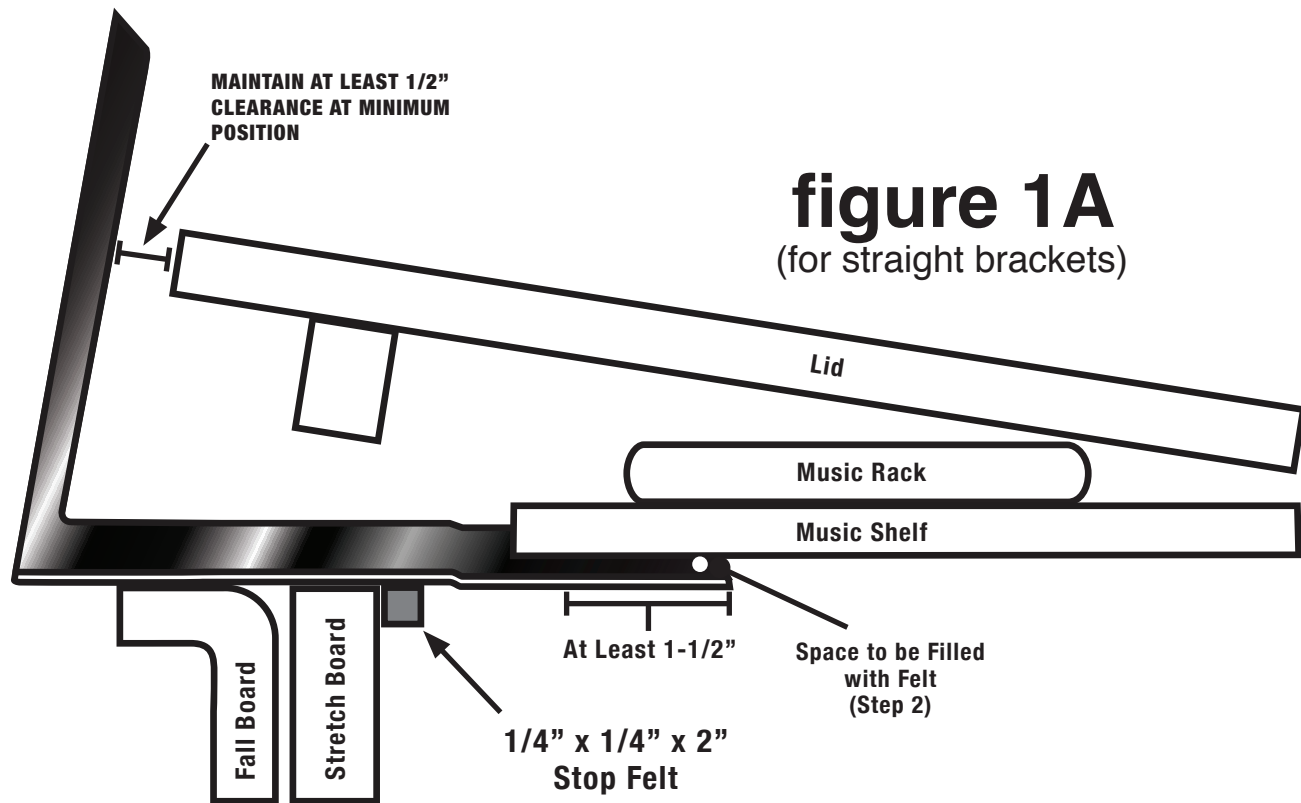

Step 2 Installing Felt:

(NOTE: Be sure bracket fits in step 1 before peeling the sticky-back off the felt pieces)

A.) Without peeling off the sticky-back, by trial and error, insert a combination of felt pieces on top of the bracket in order to fill the void between the music shelf and bracket. **(See figure 2)**. The Grandverismo comes with two sets of felt (one set for each bracket). Thicknesses are 1/16", 1/8", 1/4", & 1/2" thick. **(See figure 3)**. Trial fit the felt pieces, while holding the bracket level and flat on stretch board. Find the combination of felt thickness that fills the void and makes bracket fit snug and level.

(Note that some pianos do not need any felt. Be sure to set the felt where it gets good coverage and stability underneath the music shelf, as this position may not necessarily be at the tail end of the brackets).

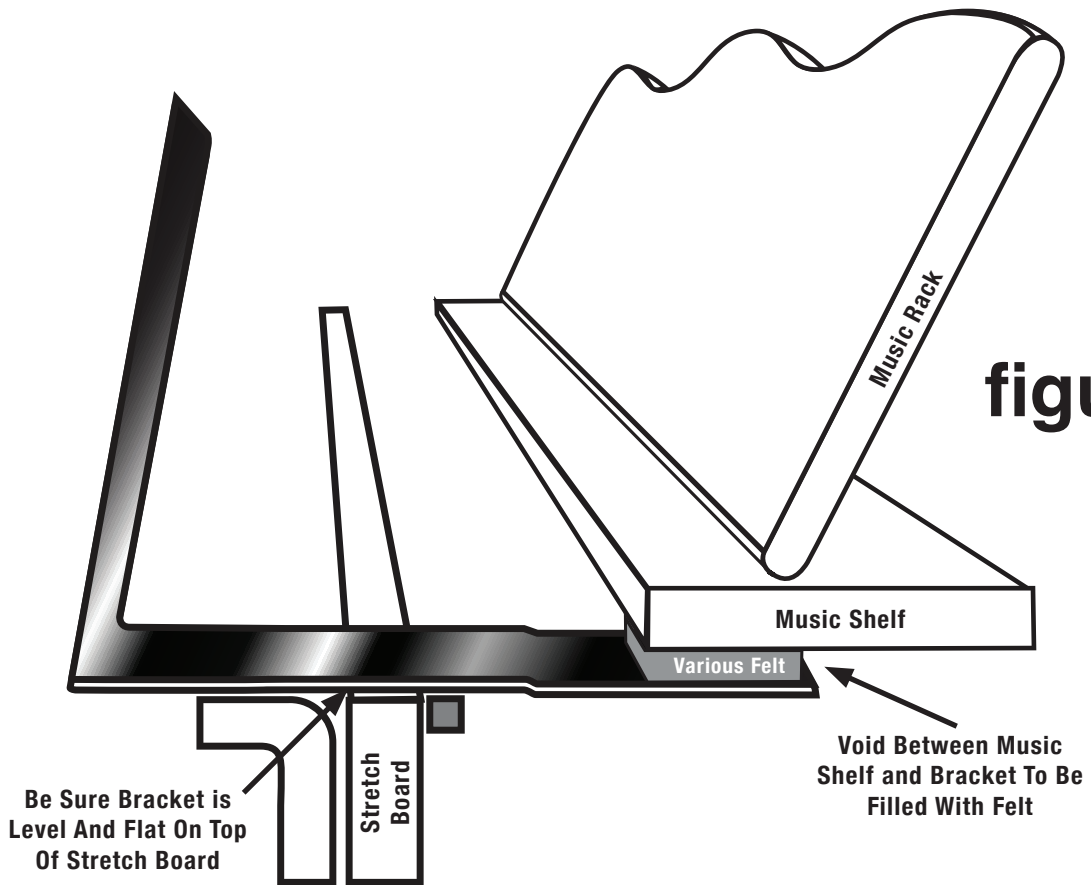

figure 2

B.) Once you determine which pieces of felt you need, peel off the adhesive back and stick to brackets. Stack and stick felt on top of felt as needed. Do the same for both brackets. (See figure 3).

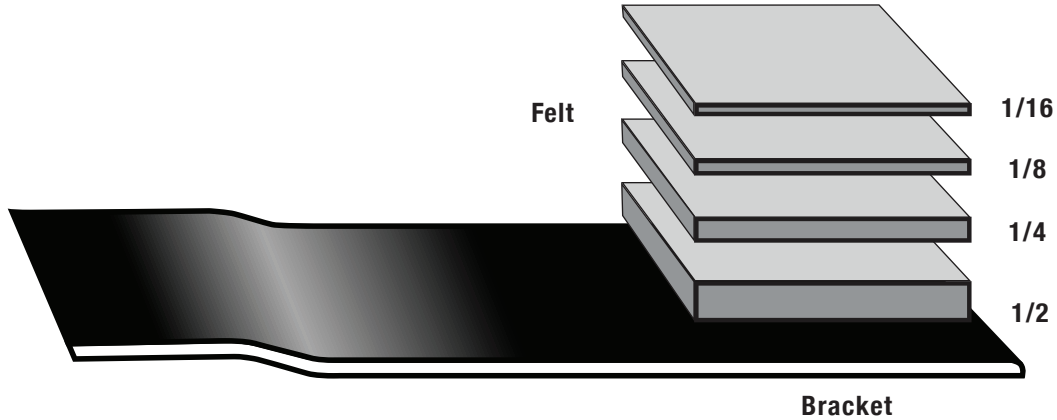

figure 3

C.) Optional: A thin strip of 1/32" felt is included. You can cut this and stick it on the brackets for additional protection where your brackets meet the stretch board and lid. (**See figure 4**). If you choose to use this optional felt, put it on last, after completing assembly.

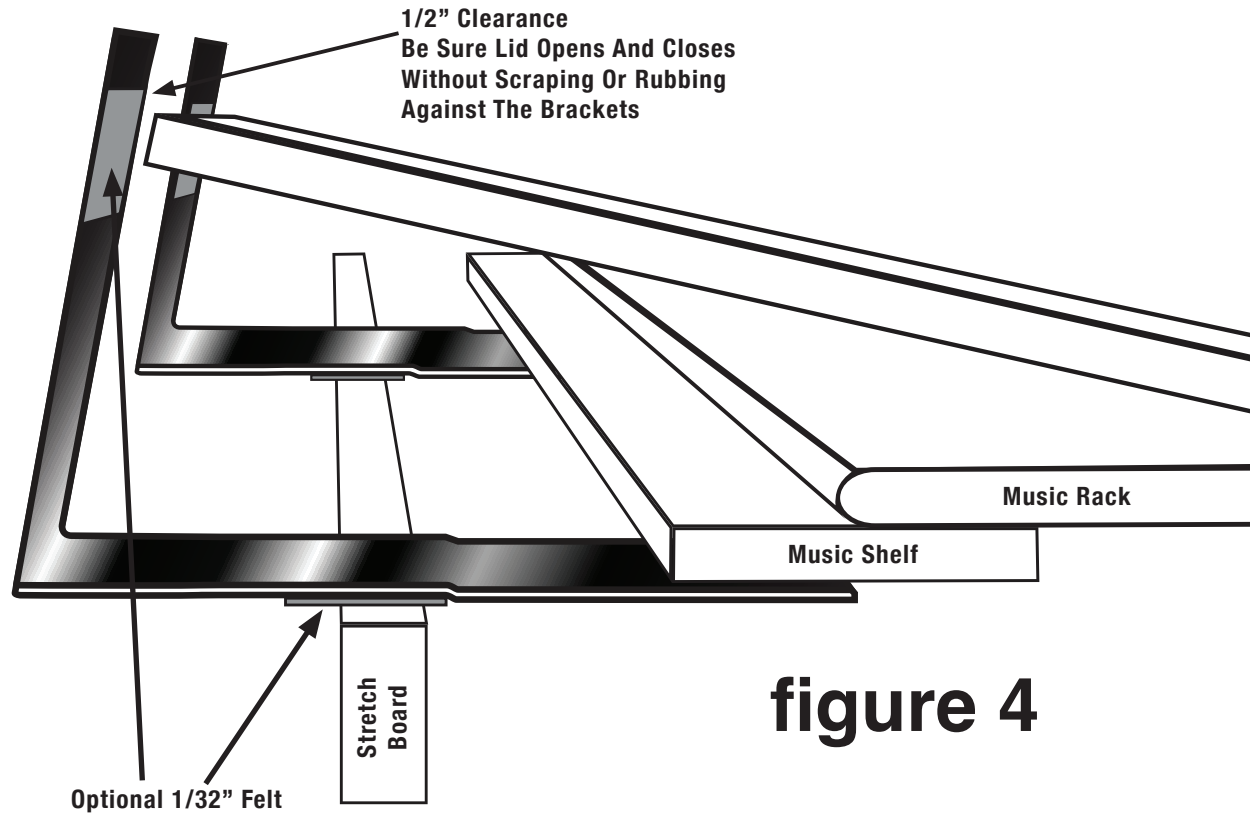

figure 4

Step 3

Mounting Brackets to Grandverismo Board

- A.) Screw two sex bolts per bracket to attach brackets. (**See figure 5**).
You will need a flat head screwdriver to tighten snug, but do not over-tighten or you may chip your Grandverismo Board.

Note that you have three height adjustments to choose from.
(See illustrations to the right).

Standard Height

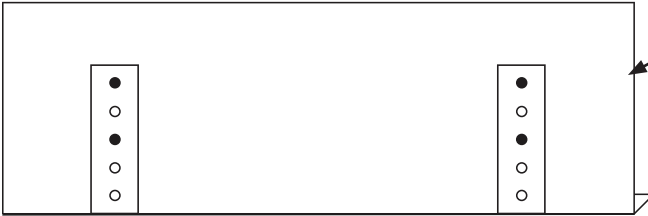

Mid - Low

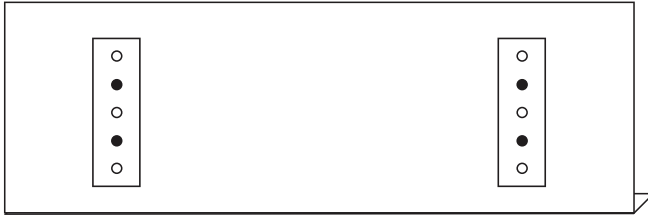

Low



Acrylic Board

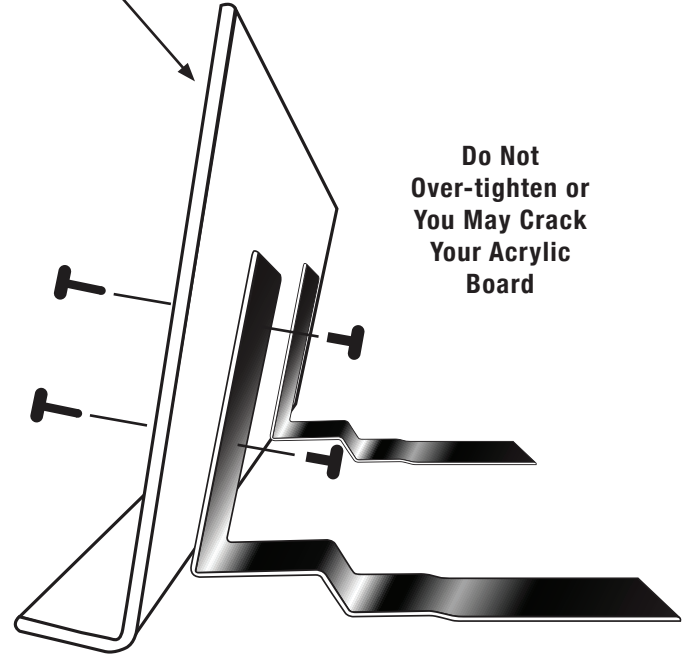

**Do Not
Over-tighten or
You May Crack
Your Acrylic
Board**

figure 5



By Slick Widget, LLC • 282 NE Turney Road, Somerville AL 35670 • 256-565-7793 • grandverismo.com

Patent# US10,796,675 B1